

Each end of every wire is welded to the frame.

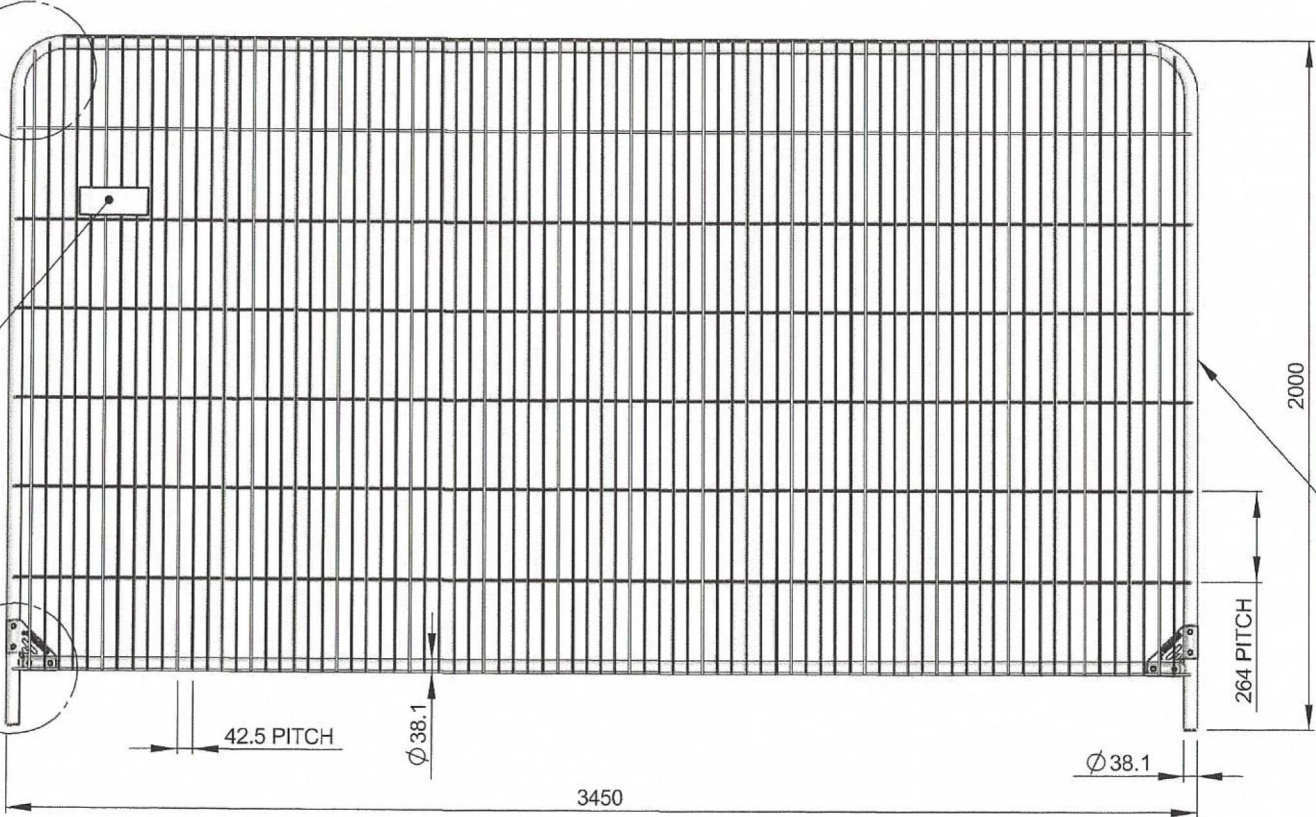

Corporate identification.



All butt welds are 360° around the tube.

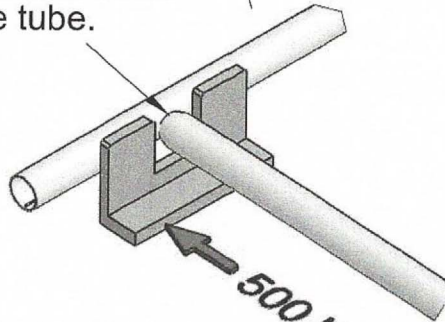

Each tube butt weld is tested to 500 Kg load before fitting the corner plates.

Every panel is marked with a proof of load test code showing date and time of test.

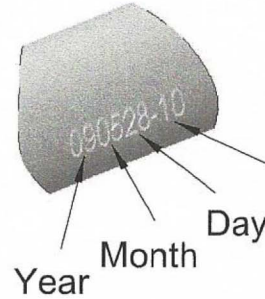

REV	DATE	DESCRIPTION	DRN	CHKD
3				

DEBUR AND BREAK SHARP EDGES

THIRD ANGLE PROJECTION  
DO NOT SCALE DRAWING  
UNLESS OTHERWISE SPECIFIED:  
DIMENSIONS ARE IN MILLIMETERS  
TOLERANCES:  
LINEAR: 0 Place ±1mm  
1 Place Dig Specied ±0.5DEG  
ANGULAR:

TITLE: SMARTWELD 100  
ANTI-CLIMB ROUND TOP PANEL

DRAWN	NAME	SIGNATURE	DATE	MATERIAL:
CHKD	-	-	-	CARBON STEEL
APPVD	-	-	-	FINISH:
MFG	-	-	-	PRE-GALVANISED TO BS EN 10244-2
Q.A	-	-	-	

Dwg/Stock No.	
WBQHT: 17 Kg	SCALE: 1:15

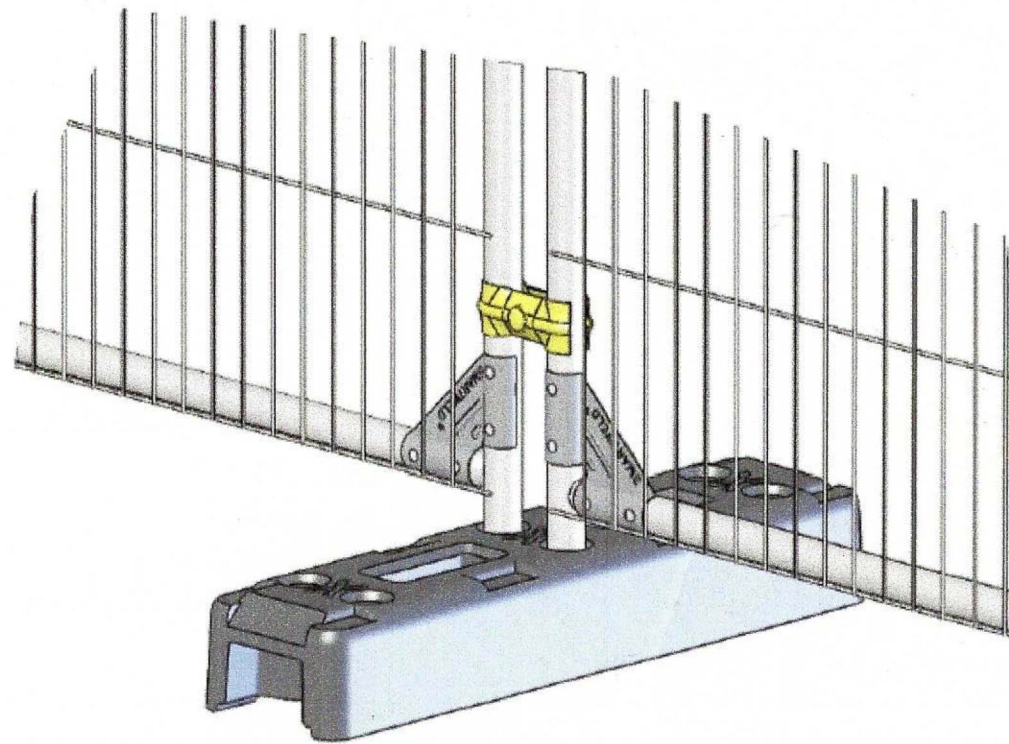

DEBUR AND BREAK SHARP EDGES

THIRD ANGLE PROJECTION  
DO NOT SCALE DRAWING  
UNLESS OTHERWISE SPECIFIED  
DIMENSIONS ARE IN MILLIMETERS  
TOLERANCES:  
LINEAR: 0 Place 4.0mm  
1 Place 0.5mm  
ANGULAR: 1 Place 0.5 DEG  
0.5 DEG

TITLE: THERMO-PLASTIC FENCE FOOT (STD)

NAME	SIGNATURE	DATE	MATERIAL:
DRAWN			RE-CYCLED PLASTICS
CHKD			
APPVD			
PRG			NONE
DLA			

REV	DATE	DESCRIPTION	DRN	CHKD	APPR
0			GC		

Part/Stock No.	Revision
----------------	----------